



Spannsätze & Buchsen

Locking Assemblies & Bushes

Lagerprogramm

Stock Programme

Inhalt

Content

Klemmbuchsen
Taper Bushes

• Seiten | pages K 1 - K 2

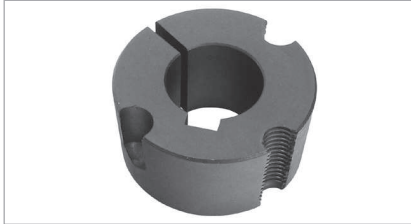

Klemmbuchsen - Auswahltabellen
Taper Bushes - Selection Tables

• Seiten | pages K 3

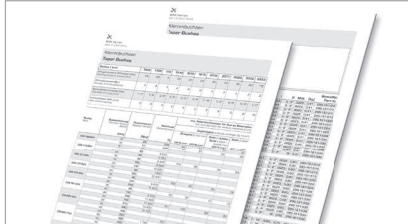

Anbaunaben für Klemmbuchsen
Bolt on Hubs for Taper Bushes

• Seiten | pages K 4



Einschweißnaben für Klemmbuchsen
Weld on Hubs for Taper Bushes

• Seiten | pages K 4



Spannbuchsen
Clamping Bushes

• Seiten | pages K 5



Spannbuchsen - Montageanleitung
Clamping Bushes - Mounting Instructions

• Seiten | pages K 6

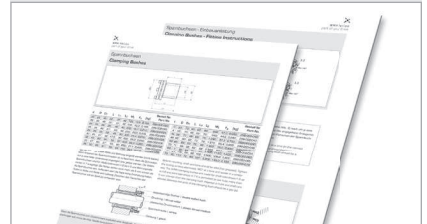

Spannsätze - selbstzentrierend &
nicht selbstzentrierend
Locking Assemblies - Self-centering &
Non-Self-centering

• Seiten | pages K 7 - K 13



Spannsätze - Berechnung des
Nabenmindstdurchmessers DM
Locking Assemblies - Calculation of
Minimum Hub Diameter DM

• Seiten | pages K 14 - K 15

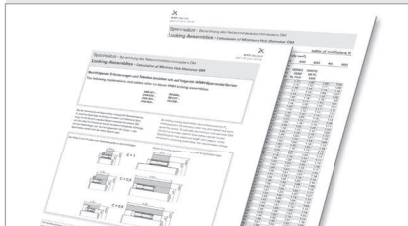

Schrumpfscheiben
Shrink Discs

• Seiten | pages K 16



Spannsätze Trantorques
Trantorques

• Seiten | pages K 17 - K 18



Spannsätze & Buchsen

Locking Assemblies & Bushes

Sonderanfertigungen

Custom Made Parts

Inhalt

Content

Bei Bedarf an den unten aufgeführten Sonder-Spannsätzen und Buchsen bitten wir um Ihre Anfrage:

If special locking assemblies and bushes (as stated below) are required, please send your request:

Klemmbuchsen

- Weitere Baugrößen sowie
- Kurze Ausführungen

Taper Bushes

- Extended range of sizes and
- Short design types

Anbaunaben für Klemmbuchsen

- Weitere Baugrößen, auch als einseitig bearbeitete Ausführung

Bolt on Hubs for Taper Bushes

- Extended range of sizes, also available in single-side design

Einschweißnaben für Klemmbuchsen

- Weitere Baugrößen

Weld on Hubs for Taper Bushes

- Extended range of sizes

Spannbuchsen

- Weitere Baugrößen erhältlich (geeignet für Wellen-Durchmesser 15 - 100 mm)
- Rostfreie Ausführungen (geeignet für Wellen-Durchmesser 15 - 50 mm)

Clamping Bushes

- More sizes available (suitable for shaft diameters 15 - 100 mm)
- Stainless steel types (suitable for shaft diameters 15 - 50 mm)

Spannsätze

- Weitere Bauformen
- Selbstzentrierend / nicht-selbstzentrierend
- Niedrige bis sehr hohe übertragbare Drehmomente

Locking Assemblies

- Other design types
- Self-centering / not self-centering
- Low to very high transmittable torques

Schrumpfscheiben

- Schrumpfscheiben-Innendurchmesser 14 - 480 mm
- Eignung für Wellendurchmesser 11 - 400 mm
- Übertragbares Drehmoment 30 - 1.310.000 Nm
- Axialkraft 6 - 6.550 kN

Shrink Discs

- Inner diameter of shrink disc 14 - 480 mm
- Suitable for shaft diameter 11 - 400 mm
- Transmittable torque 30 - 1,310,000 Nm
- Thrust 6 - 6,550 kN



K



Unsere Konstrukteure beraten Sie gerne bei der Realisierung Ihrer Anwendung - Fordern Sie uns heraus!

We offer more than competitive prices - contact our engineering department!

Klemmbuchsen Taper Bushes

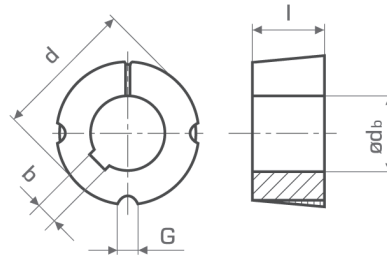

Bestell Nr.										Bestell Nr.										
d _b	b	x	t ₂	d	l	G	Mat.	[kg]	Part No.	d _b	b	x	t ₂	d	l	G	Mat.	[kg]	Part No.	
10	3	x	1,4	35,0	22,3	1/4"	GG25	0,12	295-100-810	14	5	x	2,3	57	25,4	3/8"	GG25	0,41	295-161-014	
11	4	x	1,8	35,0	22,3	1/4"	GG25	0,12	295-100-811	16	6	x	2,8	57	25,4	3/8"	GG25	0,41	295-161-016	
12	4	x	1,8	35,0	22,3	1/4"	GG25	0,12	295-100-812	18	6	x	2,8	57	25,4	3/8"	GG25	0,41	295-161-018	
14	5	x	2,3	35,0	22,3	1/4"	GG25	0,12	295-100-814	19	6	x	2,8	57	25,4	3/8"	GG25	0,41	295-161-019	
16	5	x	2,3	35,0	22,3	1/4"	GG25	0,12	295-100-816	20	6	x	2,8	57	25,4	3/8"	GG25	0,41	295-161-020	
18	6	x	2,8	35,0	22,3	1/4"	GG25	0,12	295-100-818	22	6	x	2,8	57	25,4	3/8"	GG25	0,41	295-161-022	
19	6	x	2,8	35,0	22,3	1/4"	GG25	0,12	295-100-819	24	8	x	3,3	57	25,4	3/8"	GG25	0,41	295-161-024	
20	6	x	2,8	35,0	22,3	1/4"	GG25	0,12	295-100-820	25	8	x	3,3	57	25,4	3/8"	GG25	0,41	295-161-025	
22	6	x	2,8	35,0	22,3	1/4"	GG25	0,12	295-100-822	28	8	x	3,3	57	25,4	3/8"	GG25	0,41	295-161-028	
24	8	x	1,3*	35,0	22,3	1/4"	GG25	0,12	295-100-824	30	8	x	3,3	57	25,4	3/8"	GG25	0,41	295-161-030	
25	8	x	1,3*	35,0	22,3	1/4"	GG25	0,12	295-100-825	32	10	x	3,3	57	25,4	3/8"	GG25	0,41	295-161-032	
										35	10	x	3,3	57	25,4	3/8"	GG25	0,41	295-161-035	
										38	10	x	3,3	57	25,4	3/8"	GG25	0,41	295-161-038	
										40	12	x	3,3	57	25,4	3/8"	GG25	0,41	295-161-040	
										42	12	x	2,2*	57	25,4	3/8"	St	0,41	295-161-042	
										14	5	x	2,3	57	38,1	3/8"	GG25	0,60	295-161-514	
										16	6	x	2,8	57	38,1	3/8"	GG25	0,60	295-161-516	
										18	6	x	2,8	57	38,1	3/8"	GG25	0,60	295-161-518	
										19	6	x	2,8	57	38,1	3/8"	GG25	0,60	295-161-519	
										20	6	x	2,8	57	38,1	3/8"	GG25	0,60	295-161-520	
										22	6	x	2,8	57	38,1	3/8"	GG25	0,60	295-161-522	
										24	8	x	3,3	57	38,1	3/8"	GG25	0,60	295-161-524	
										25	8	x	3,3	57	38,1	3/8"	GG25	0,60	295-161-525	
										28	8	x	3,3	57	38,1	3/8"	GG25	0,60	295-161-528	
										30	8	x	3,3	57	38,1	3/8"	GG25	0,60	295-161-530	
										32	10	x	3,3	57	38,1	3/8"	GG25	0,60	295-161-532	
										35	10	x	3,3	57	38,1	3/8"	GG25	0,60	295-161-535	
										38	10	x	3,3	57	38,1	3/8"	GG25	0,60	295-161-538	
										40	12	x	3,3	57	38,1	3/8"	GG25	0,60	295-161-540	
										42	12	x	2,2*	57	38,1	3/8"	St	0,60	295-161-542	
										14	5	x	2,3	70	31,8	7/16"	GG25	0,75	295-201-214	
										16	5	x	2,3	70	31,8	7/16"	GG25	0,75	295-201-216	
										18	6	x	2,8	70	31,8	7/16"	GG25	0,75	295-201-218	
										19	6	x	2,8	70	31,8	7/16"	GG25	0,75	295-201-219	
										20	6	x	2,8	70	31,8	7/16"	GG25	0,75	295-201-220	
										22	6	x	2,8	70	31,8	7/16"	GG25	0,75	295-201-222	
										24	8	x	3,3	70	31,8	7/16"	GG25	0,75	295-201-224	
										25	8	x	3,3	70	31,8	7/16"	GG25	0,75	295-201-225	
										28	8	x	3,3	70	31,8	7/16"	GG25	0,75	295-201-228	
										30	8	x	3,3	70	31,8	7/16"	GG25	0,75	295-201-230	
										32	10	x	3,3	70	31,8	7/16"	GG25	0,75	295-201-232	
										35	10	x	3,3	70	31,8	7/16"	GG25	0,75	295-201-235	
										38	10	x	3,3	70	31,8	7/16"	GG25	0,75	295-201-238	
										40	12	x	3,3	70	31,8	7/16"	GG25	0,75	295-201-240	
										42	12	x	3,3	70	31,8	7/16"	GG25	0,75	295-201-242	
										45	14	x	3,8	70	31,8	7/16"	GG25	0,75	295-201-245	
										48	14	x	3,8	70	31,8	7/16"	GG25	0,75	295-201-248	
										50	14	x	3,8	70	31,8	7/16"	GG25	0,75	295-201-250	

Klemmbuchsen Taper Bushes

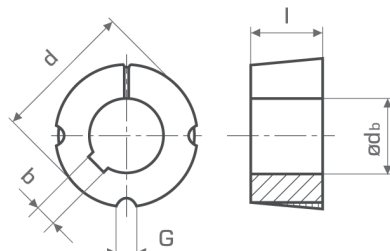

Bestell Nr.										Bestell Nr.									
d _b	b	x	t ₂	d	l	G	Mat.	[kg]	Part No.	d _b	b	x	t ₂	d	l	G	Mat.	[kg]	Part No.
16	5	x	2,3	86	44,5	1/2"	GG25	1,06	295-251-716	30	8	x	3,3	108	76,2	5/8"	GG25	3,75	295-303-030
18	6	x	2,8	86	44,5	1/2"	GG25	1,06	295-251-718	32	10	x	3,3	108	76,2	5/8"	GG25	3,75	295-303-032
19	6	x	2,8	86	44,5	1/2"	GG25	1,06	295-251-719	35	10	x	3,3	108	76,2	5/8"	GG25	3,75	295-303-035
20	6	x	2,8	86	44,5	1/2"	GG25	1,06	295-251-720	38	10	x	3,3	108	76,2	5/8"	GG25	3,75	295-303-038
22	6	x	2,8	86	44,5	1/2"	GG25	1,06	295-251-722	40	12	x	3,3	108	76,2	5/8"	GG25	3,75	295-303-040
24	8	x	3,3	86	44,5	1/2"	GG25	1,06	295-251-724	42	12	x	3,3	108	76,2	5/8"	GG25	3,75	295-303-042
25	8	x	3,3	86	44,5	1/2"	GG25	1,06	295-251-725	45	14	x	3,8	108	76,2	5/8"	GG25	3,75	295-303-045
28	8	x	3,3	86	44,5	1/2"	GG25	1,06	295-251-728	48	14	x	3,8	108	76,2	5/8"	GG25	3,75	295-303-048
30	8	x	3,3	86	44,5	1/2"	GG25	1,06	295-251-730	50	14	x	3,8	108	76,2	5/8"	GG25	3,75	295-303-050
32	10	x	3,3	86	44,5	1/2"	GG25	1,06	295-251-732	55	16	x	4,3	108	76,2	5/8"	GG25	3,75	295-303-055
35	10	x	3,3	86	44,5	1/2"	GG25	1,06	295-251-735	60	18	x	4,4	108	76,2	5/8"	GG25	3,75	295-303-060
38	10	x	3,3	86	44,5	1/2"	GG25	1,06	295-251-738	65	18	x	4,4	108	76,2	5/8"	GG25	3,75	295-303-065
40	12	x	3,3	86	44,5	1/2"	GG25	1,06	295-251-740	70	20	x	4,9	108	76,2	5/8"	GG25	3,75	295-303-070
42	12	x	3,3	86	44,5	1/2"	GG25	1,06	295-251-742	75	20	x	4,9	108	76,2	5/8"	GG25	3,75	295-303-075
45	14	x	3,8	86	44,5	1/2"	GG25	1,06	295-251-745										
48	14	x	3,8	86	44,5	1/2"	GG25	1,06	295-251-748	35	12	x	3,3	127	88,9	1/2"	GG25	5,13	295-353-535
50	14	x	3,8	86	44,5	1/2"	GG25	1,06	295-251-750	38	12	x	3,3	127	88,9	1/2"	GG25	5,13	295-353-538
55	16	x	4,3	86	44,5	1/2"	GG25	1,06	295-251-755	40	12	x	3,3	127	88,9	1/2"	GG25	5,13	295-353-540
60	18	x	4,4	86	44,5	1/2"	GG25	1,06	295-251-760	42	12	x	3,3	127	88,9	1/2"	GG25	5,13	295-353-542
										45	14	x	3,8	127	88,9	1/2"	GG25	5,13	295-353-545
25	8	x	3,3	108	50,8	5/8"	GG25	2,50	295-302-025	48	14	x	3,8	127	88,9	1/2"	GG25	5,13	295-353-548
28	8	x	3,3	108	50,8	5/8"	GG25	2,50	295-302-028	50	14	x	3,8	127	88,9	1/2"	GG25	5,13	295-353-550
30	8	x	3,3	108	50,8	5/8"	GG25	2,50	295-302-030	55	16	x	4,3	127	88,9	1/2"	GG25	5,13	295-353-555
32	10	x	3,3	108	50,8	5/8"	GG25	2,50	295-302-032	60	18	x	4,4	127	88,9	1/2"	GG25	5,13	295-353-560
35	10	x	3,3	108	50,8	5/8"	GG25	2,50	295-302-035	65	18	x	4,4	127	88,9	1/2"	GG25	5,13	295-353-565
38	10	x	3,3	108	50,8	5/8"	GG25	2,50	295-302-038	70	20	x	4,9	127	88,9	1/2"	GG25	5,13	295-353-570
40	12	x	3,3	108	50,8	5/8"	GG25	2,50	295-302-040	75	20	x	4,9	127	88,9	1/2"	GG25	5,13	295-353-575
42	12	x	3,3	108	50,8	5/8"	GG25	2,50	295-302-042	80	22	x	4,5	127	88,9	1/2"	GG25	5,13	295-353-580
45	14	x	3,8	108	50,8	5/8"	GG25	2,50	295-302-045	85	22	x	4,5	127	88,9	1/2"	GG25	5,13	295-353-585
48	14	x	3,8	108	50,8	5/8"	GG25	2,50	295-302-048	90	25	x	4,5	127	88,9	1/2"	GG25	5,13	295-353-590
50	14	x	3,8	108	50,8	5/8"	GG25	2,50	295-302-050										
55	16	x	4,3	108	50,8	5/8"	GG25	2,50	295-302-055										
60	18	x	4,4	108	50,8	5/8"	GG25	2,50	295-302-060										
65	18	x	4,4	108	50,8	5/8"	GG25	2,50	295-302-065										
70	20	x	4,9	108	50,8	5/8"	GG25	2,50	295-302-070										
75	20	x	4,9	108	50,8	5/8"	GG25	2,50	295-302-075										



Klemmbuchsen Taper Bushes

Buchse bush	1008	1108	1210	1310	1610	1615	2012	2517	3020	3030	3535
Anzugsmoment d. Schrauben [Nm] Starting torque of screws [Nm]	5,6	5,6	20	20	20	20	30	50	90	90	115
Schraubenanzahl (Stk.) Number of screws (pieces)	2	2	2	2	2	2	2	2	2	2	3
Schraubendurchmesser (Zoll) Diameter of screw (inch)	1/4"	1/4"	3/8"	3/8"	3/8"	3/8"	7/16"	1/2"	5/8"	5/8"	1/2"
Innensechskant SWL (mm) Allen wrench opening	3	3	5	5	5	5	6	6	8	8	10

Buchse Bush	Buchsenbohrung Diameter of bore (Bush) [mm]	Rutschmoment Slipping moment [Nm]	Klemmkraft Clamping power [N]	min. Nabendurchmesser für diverse Materialien min. hub diameter for various materials [mm]			
				Zugfestigkeit tensile strength [N/mm ²]			
				Grauguss cast iron 180 N/mm ² 250 N/mm ²		Stahl / duktiler Stahl steel / ductile iron 420 N/mm ²	Stahl steel 600 N/mm ²
295-100-8XX	12	29	3990	62	54	51	47
	19	51	4940	64	57	54	50
295-110-8XX	12	28	-				
	19	49	4 630				
	24	64	5 220				
295-121-0XX	16	82	8 840	104	86	78	69
	19	105	9 800				
	24	142	10 900				
295-131-0XX	14	59	7800				
	25	120	10 900				
295-161-0XX	19	98	-	109	92	85	78
	24	135	9 570				
	38	240	11 900				
295-161-5XX	19	98	-	90	81	77	73
	24	135	9 570				
	38	240	11 900				
295-201-2XX	24	165	11 500	121	106	99	92
	38	310	14 400				
	42	340	15 700				
	48	400	-				
295-251-7XX	24	220	-	130	119	113	108
	38	380	1 700				
	42	430	18 500				
	48	510	-				
	55	600	21 000				
295-302-0XX	38	520	23 900	160	146	140	132
	48	730	26 100				
	55	890	29 900				
	60	970	31 500				
	75	1 300	34 500				
295-303-0XX	38	520	23 900	144	136	132	127
	48	730	26 100				
	55	890	29 900				
	60	970	31 500				
	75	1 300	34 500				
295-353-5XX	42	1 000	41 000	191	176	168	160
	60	1 580	49 800				
	75	2 150	54 600				
	90	2 600	59 000				

Anbaunaben für Klemmbuchsen Bolt on Hubs for Taper Bushes

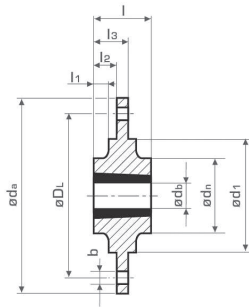

Material
 material

GG 25
 cast iron

d_a	D_L	d_1	d_n	l	l_1	l_2	l_3	b	L^*	[kg]	für Klemmbuchsen for taper bushes	Bestell Nr. Part No.
180	135	90	75	25	6,75	9,25	15,75	7,5	6	1,8	295-121-011...032	295-121-002
200	150	110	85	38	12,75	15,25	22,25	7,5	6	2,2	295-161-514...542	295-161-502
270	190	140	110	32	9,25	11,75	20,25	9,5	6	4,35	295-201-214...250	295-201-202
340	240	170	125	45	14,75	17,25	26,75	11,5	8	8,8	295-251-716...760	295-251-702
430	300	220	160	51	16,25	18,75	32,25	13,5	8	19,2	295-302-025...075	295-302-002
485	340	250	160	51	15,75	18,25	31,75	13,5	8	26,0	295-302-025...075	295-302-102

Einschweißnaben für Klemmbuchsen Weld on Hubs for Taper Bushes

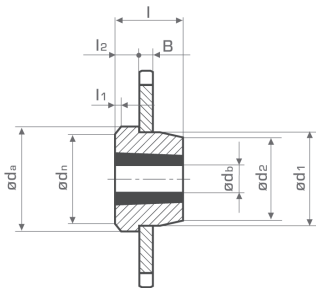

Material
 material

Stahl: 1.0503 [C45]
 steel: 1.0503 [C45]



d_a	d_1^{hb}	d_2	d_n	l	l_1	l_2	B	[kg]	für Klemmbuchsen for taper bushes	Bestell Nr. Part No.
70	60	60	65	25	7	9	10	0,275	295-121-011...032	295-121-003
83	70	68	76	38	10	16	11	0,55	295-161-514...542	295-161-503
127	110	108	117	44	10	19	13	1,75	295-251-716...760	295-251-703
152	130	125	140	76	13	25	19	3,4	295-303-030...075	295-303-003
184	155	151	168	89	16	32	25	6,7	295-353-535...590	295-353-503

L^* : Lochzahl | number of holes

Spannbuchsen Clamping Bushes

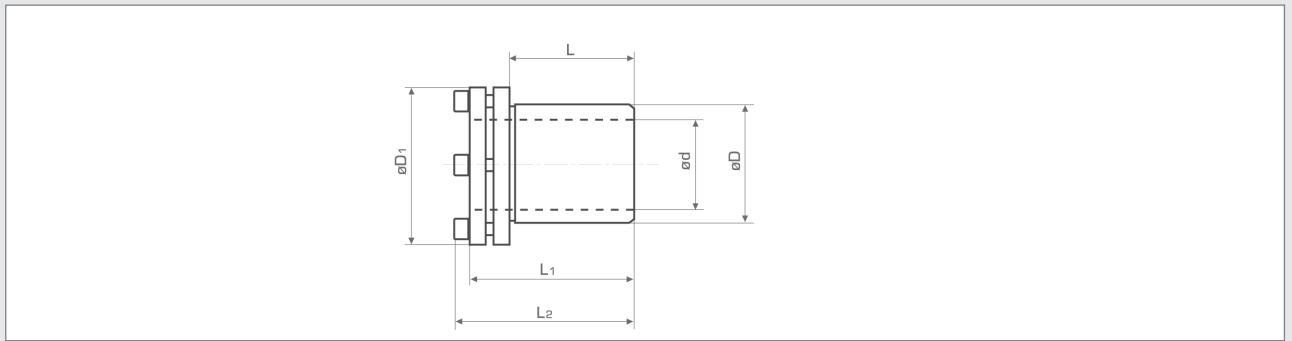

										Bestell Nr.											Bestell Nr.
d	D	D ₁	L	L ₁	L ₂	M _t	F _a	[kg]	Part No.	d	D	D ₁	L	L ₁	L ₂	M _t	F _a	[kg]	Part No.		
20	28	45	22	37	42	125	12,5	0,185	298-000-020	40	53	70	43	63	68	940	47,0	0,550	298-000-040		
22	32	49	22	37	42	135	12,3	0,195	298-000-022	42	55	70	45	65	70	940	44,8	0,550	298-000-042		
24	34	49	25	40	45	200	16,7	0,210	298-000-024	45	59	77	49	69	75	1 290	57,3	0,700	298-000-045		
25	34	49	27	43	48	250	20,0	0,205	298-000-025	48	62	80	52	73	79	1 570	65,4	0,800	298-000-048		
28	39	55	29	45	50	300	21,4	0,270	298-000-028	50	65	83	53	76	82	1 900	76,0	0,900	298-000-050		
30	41	57	32	47,5	52	420	28,0	0,290	298-000-030	55	71	88	58	82	88	2 500	90,9	1,100	298-000-055		
32	43	60	34	52	57	420	26,3	0,390	298-000-032	60	77	95	64	90	96	3 400	113,0	1,400	298-000-060		
35	47	63	37	55	60	650	37,1	0,425	298-000-035	65	84	102	68	96	102	3 500	108,0	1,800	298-000-065		
38	50	65	41	59	64	750	39,5	0,470	298-000-038	70	90	113	72	99	107	5 200	149,0	2,100	298-000-070		

Vor der Montage sollen Welle und Bohrung eingölt werden (nicht fetten). Beim Anziehen der Spannschrauben ist zu beachten, dass die Schrauben nur je eine halbe Umdrehung angezogen bzw. gelöst werden. Die WMH-Spannbuchsen sind für Wellentoleranzen h 8 bis k 6 und Bohrungstoleranzen H 7 ausgelegt. Die Naben dürfen nicht mehr als 5 mm kürzer als die Spannbuchse sein. Außerdem darf die Nabe keine Eindrehung haben. Nuten in Nabe und Welle sind zulässig. Zwischen den Flanschen der Spannbuchse soll ein Spalt (a) vorhanden sein.

Before mounting, shaft and bore should be oiled (not greased). Tighten the locking screws alternately 180° at a time and loosen in a similar way. The WMH-clamping bushes are made for shaft tolerances h 8 up to k 6 and bore tolerances H 7. It is permitted to use hubs more than 5 mm shorter than the clamping bush. Keyways in hubs and shaft are allowed. Between the ends of the clamping bush should be a gap (a).

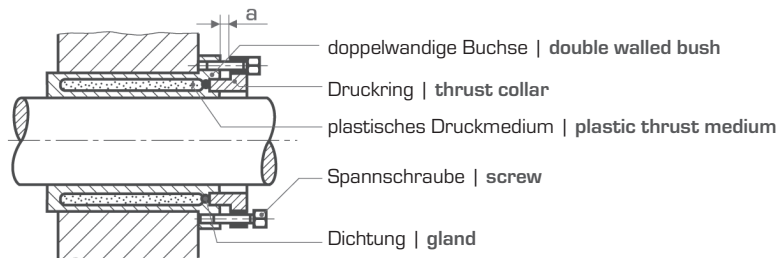

Wenn die Spannbuchse zum Drehmoment zusätzlich eine Axialkraft „F“ übertragen soll, muss die linke Tabelle berücksichtigt werden.

If the clamping bush has to transmit torque and thrust „F“, the left hand table must be used.

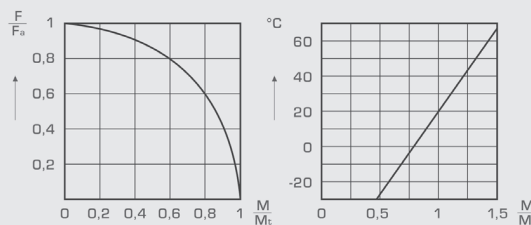

Die Flächenpressung zw. Welle und Spannbuchse beträgt bei einer Raumtemperatur von ca. 20° C und dem vorgeschriebenen Anzugsmoment der Schraube ca. 90 N/mm², die Flächenpressung zw. Nabe und Spannbuchse 80 N/mm². Obenstehendes Diagramm (rechts) zeigt das Übertragungsmoment in Abhängigkeit der Umgebungstemperatur. Die WMH-Spannbuchsen können bis zu einer maximalen Umgebungstemperatur von 85° C eingesetzt werden.

The pressure between shaft and clamping bush is at an ambient of approximately 20° C and the tightening torque of the screws approx. 90 N/mm², the contact pressure between hub and clamping bush 80 N/mm². The above performance chart (right hand) shows the transmitted torque at ambient temperature. The WMH-Clamping bushes can be used up to a maximum ambient temperature of 85° C.

Spannbuchsen - Einbauanleitung Clamping Bushes - Fitting Instructions

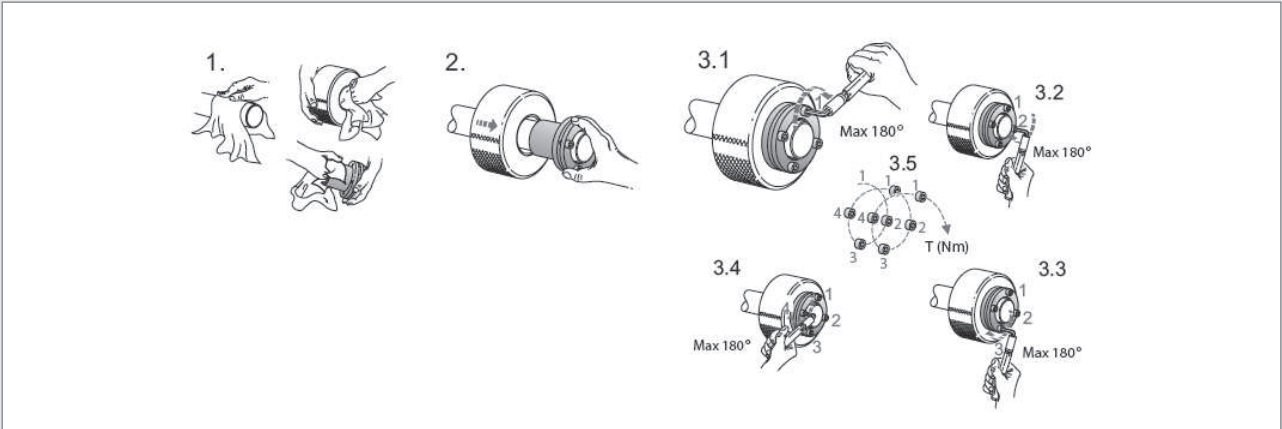

Anzugsmoment der Schrauben [Nm]
Tightening torque of the screws [Nm]

298-000-020 bis up to 298-000-042	8
298-000-045 bis up to 298-000-065	13
298-000-070	32

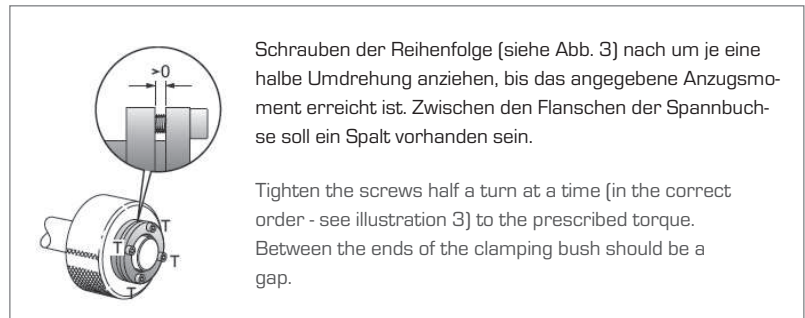

Demontage Removal

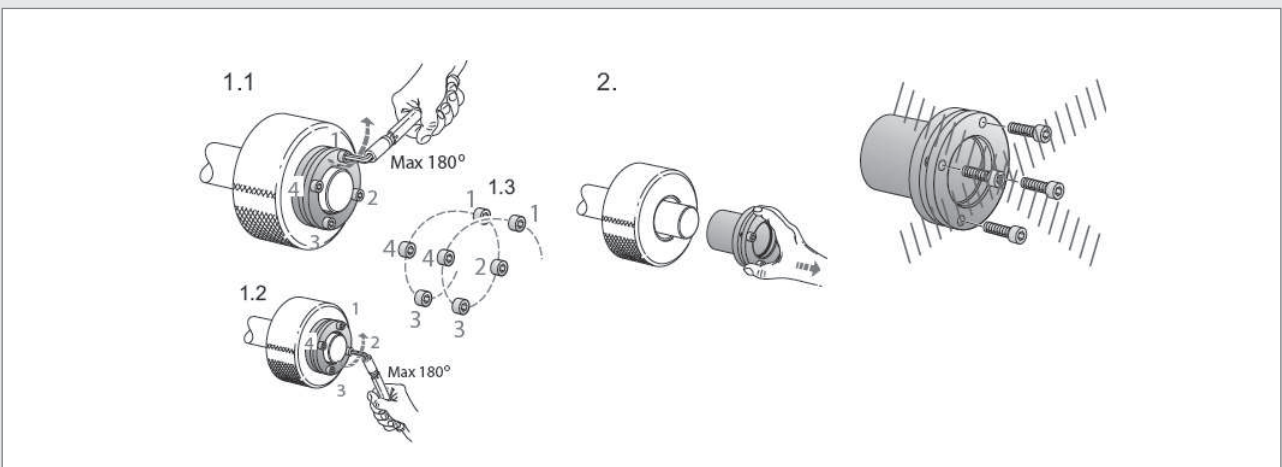

Schrauben in umgekehrter Reihenfolge je eine halbe Umdrehung lösen bis sich die Spannbuchse drehen lässt.

Loosen the screws, half a turn at a time, in consecutive order, until the clamping bush is loose.

Spannsätze - selbstzentrierend Locking Assemblies - Self-centering

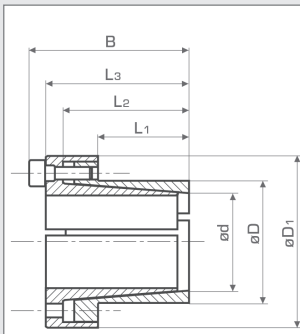

Kennzeichen:
Mittlere bis hohe Drehmomente
Kurze Montagezeiten
Geringe radiale Einbaumaße
Sehr niedrige Flächenpressung

Toleranzen, Rauhtiefe:
Höchste zulässige Rauhtiefe:
Rt max 16 µm (Ra 3 µm - Rz 13 µm)
Wellentoleranz = h 8; Nabentoleranz = H 8

Axiale Verschiebung:
Während der Montage erfolgt keine axiale
Verschiebung der Nabe gegenüber der Welle.

Characteristics:
Medium-high torque
Limited installation time
Restricted hub diameter
Very low surface pressure

Tolerances, surface finish:
Maximum allowable surface finish:
Rt max 16 µm (Ra 3 µm - Rz 13 µm)
Shaft tolerance = h 8; hub tolerance = H 8

Axial movement:
During screws tightening the hub has no axial
movement with respect to the shaft.

d	D	L ₁	L ₂	L ₃	B	D ₁	Spannschrauben			M _M	M _t	F _a	P _W	P _N	[kg]	Bestell Nr.
							Set screws									Part No.
6	14	10	18,5	21	24	25	3	x	M3	2	12	4	185	80	0,04	298-001-006
7	15	12	22	25	29	27	3	x	M4	5	25	7	235	110	0,06	298-001-007
8	15	12	22	25	29	27	3	x	M4	5	29	7	205	110	0,05	298-001-008
9	16	14	23	26	30	28	4	x	M4	5	44	10	205	115	0,06	298-001-009
10	16	14	23	26	30	28	4	x	M4	5	49	10	185	115	0,06	298-001-010
11	18	14	23	26	30	32	4	x	M4	5	53	10	170	105	0,07	298-001-011
12	18	14	23	26	30	32	4	x	M4	5	58	10	160	105	0,07	298-001-012
13	23	14	23	26	30	38	4	x	M4	5	63	10	140	80	0,11	298-001-013
14	23	14	23	26	30	38	4	x	M4	5	68	10	130	80	0,10	298-001-014
15	24	16	29	36	42	45	3	x	M6	17	127	17	185	115	0,22	298-001-015
16	24	16	29	36	42	45	3	x	M6	17	136	17	175	115	0,22	298-001-016
17	26	18	31	38	44	47	4	x	M6	17	180	22	190	125	0,25	298-001-017
18	26	18	31	38	44	47	4	x	M6	17	200	22	180	125	0,24	298-001-018
19	27	18	31	38	44	49	4	x	M6	17	210	22	170	120	0,26	298-001-019
20	28	18	31	38	44	50	4	x	M6	17	220	22	160	115	0,27	298-001-020
22	32	25	38	45	51	54	4	x	M6	17	250	22	115	80	0,34	298-001-022
24	34	25	38	45	51	56	4	x	M6	17	270	22	105	75	0,36	298-001-024
25	34	25	38	45	51	56	4	x	M6	17	280	22	100	75	0,35	298-001-025
28	39	25	38	45	51	61	6	x	M6	17	465	33	135	97	0,48	298-001-028
30	41	25	38	45	51	62	6	x	M6	17	510	33	127	90	0,48	298-001-030
32	43	25	38	45	51	65	6	x	M6	17	540	33	120	90	0,47	298-001-032
35	47	32	45	52	58	69	8	x	M6	17	790	45	105	80	0,58	298-001-035
38	50	32	45	52	58	72	8	x	M6	17	860	45	100	75	0,61	298-001-038
40	53	32	45	52	58	75	8	x	M6	17	900	45	95	70	0,68	298-001-040
42	55	32	45	52	58	78	8	x	M6	17	950	45	90	70	0,76	298-001-042
45	59	45	62	70	78	86	8	x	M8	41	1 890	84	110	85	1,20	298-001-045
48	62	45	62	70	78	87	8	x	M8	41	2 010	84	105	80	1,20	298-001-048
50	65	45	62	70	78	92	8	x	M8	41	2 100	84	100	75	1,40	298-001-050
55	71	55	72	80	88	98	9	x	M8	41	2 600	94	85	65	1,60	298-001-055
60	77	55	72	80	88	104	9	x	M8	41	2 840	94	75	60	1,80	298-001-060
65	84	55	72	80	88	111	9	x	M8	41	3 070	94	70	55	2,10	298-001-065
70	90	65	86	96	106	119	9	x	M10	83	5 250	150	90	70	3,00	298-001-070
75	95	65	86	96	106	126	9	x	M10	83	5 600	150	80	65	3,00	298-001-075
80	100	65	86	96	106	131	12	x	M10	83	8 020	200	100	80	3,50	298-001-080
85	106	65	86	96	106	137	12	x	M10	83	8 500	200	95	75	3,60	298-001-085
90	112	65	86	96	106	144	12	x	M10	83	9 000	200	90	75	3,90	298-001-090
95	120	65	86	96	106	149	14	x	M10	83	11 000	230	100	80	4,40	298-001-095
100	125	65	86	96	106	154	18	x	M10	83	15 000	300	120	95	4,60	298-001-100
110	140	90	114	128	140	180	12	x	M12	145	16 000	290	80	65	8,70	298-001-110
120	155	90	114	128	140	198	12	x	M12	145	17 500	290	70	55	10,60	298-001-120
130	165	90	114	128	140	208	16	x	M12	145	25 000	384	90	70	11,30	298-001-130

Anzugsmoment | starting torque
Drehmoment | torque
Axialkraft | thrust
Flächenpressung - Welle | contact pressure - shaft
Flächenpressung - Nabe | contact pressure - hub

M_M [Nm]
M_t [Nm]
F_a [kN]
P_W [N/mm²]
P_N [N/mm²]

Spannsätze - nicht selbstzentrierend

Locking Assemblies - Not-Self-centering

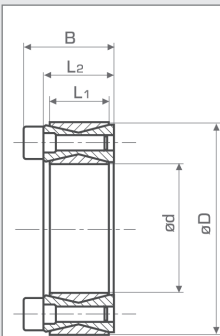

Kennzeichen:
Mittlere bis hohe Drehmomente
Breite Toleranzen

Toleranzen, Rauhtiefe:
Höchste zulässige Rauhtiefe:
Rt max 16 µm (Ra 3 µm - Rz 13 µm)
Wellentoleranz = h 11; Nabentoleranz = H 11

Zentrierung:
Eine Selbstzentrierung ist bei dieser Art nicht gegeben.
Die Rundlaufgenauigkeit der Verbindung ist von der Toleranz und Führungsbreite der Vorzentrierung zwischen Welle und Nabe abhängig.

Axiale Verschiebung:
Während des Schraubenanziehens erfolgt keine axiale Verschiebung der Nabe gegenüber der Welle.

Characteristics:
Medium-high torque
Wide tolerances

Tolerances, surface finish:
Maximum allowable surface finish:
Rt max 16 µm (Ra 3 µm - Rz 13 µm)
Shaft tolerance = h 11; hub tolerance = H 11

Centering:
Such a system is not selfcentering and therefore the concentricity of the piece to be fastened depends on the working tolerances between shaft and hub as well as the width of the centering guide.

Axial movement:
During screws tightening the hub has no axial movement with respect to the shaft.

d	D	L ₁	L ₂	B	Spannschrauben								[kg]	Bestell Nr. Part No.
					Set screws		M _M	M _t	F _a	P _W	P _N			
20	47	17	20	27,5	8	x	M6	15	280	29	225	95	0,2	298-002-020
22	47	17	20	27,5	8	x	M6	15	310	29	210	95	0,2	298-002-022
24	50	17	20	27,5	8	x	M6	15	370	32	210	100	0,3	298-002-024
25	50	17	20	27,5	8	x	M6	15	400	32	200	100	0,3	298-002-025
28	55	17	20	27,5	10	x	M6	15	500	36	200	100	0,3	298-002-028
30	55	17	20	27,5	10	x	M6	15	530	36	185	100	0,3	298-002-030
32	60	17	20	27,5	12	x	M6	15	680	42	205	110	0,3	298-002-032
35	60	17	20	27,5	12	x	M6	15	750	43	190	110	0,3	298-002-035
38	65	17	20	27,5	14	x	M6	15	930	49	200	115	0,4	298-002-038
40	65	17	20	27,5	14	x	M6	15	980	49	190	115	0,3	298-002-040
42	75	20	24	33,5	12	x	M8	37	1 580	75	235	130	0,6	298-002-042
45	75	20	24	33,5	12	x	M8	37	1 700	76	220	130	0,6	298-002-045
48	80	20	24	33,5	12	x	M8	37	1 790	74	210	120	0,6	298-002-048
50	80	20	24	33,5	12	x	M8	37	1 870	75	200	120	0,6	298-002-050
55	85	20	24	33,5	14	x	M8	37	2 390	88	210	135	0,6	298-002-055
60	90	20	24	33,5	14	x	M8	37	2 610	88	190	125	0,7	298-002-060
65	95	20	24	33,5	16	x	M8	37	3 210	98	200	135	0,7	298-002-065
70	110	24	28	39,5	14	x	M10	70	4 600	132	210	130	1,3	298-002-070
75	115	24	28	39,5	14	x	M10	70	4 900	131	195	125	1,3	298-002-075
80	120	24	28	39,5	14	x	M10	70	5 200	131	180	120	1,4	298-002-080
85	125	24	28	39,5	16	x	M10	70	6 300	148	195	130	1,4	298-002-085
90	130	24	28	39,5	16	x	M10	70	6 600	147	180	125	1,5	298-002-090
95	135	24	28	39,5	18	x	M10	70	7 900	167	195	135	1,6	298-002-095
100	145	26	33	47	14	x	M12	127	9 750	195	195	135	2,2	298-002-100
110	155	26	33	47	14	x	M12	127	10 650	194	180	125	2,5	298-002-110
120	165	26	33	47	16	x	M12	127	13 300	221	185	135	2,6	298-002-120
130	180	34	38	52	20	x	M12	127	17 850	276	165	115	3,8	298-002-130
140	190	34	38	52	22	x	M12	127	21 200	302	165	125	3,9	298-002-140
150	200	34	38	52	24	x	M12	127	24 500	329	170	125	4,0	298-002-150
160	210	34	38	52	26	x	M12	127	28 400	355	170	130	4,3	298-002-160
170	225	38	44	60	22	x	M14	195	33 600	396	165	120	5,8	298-002-170
180	235	38	44	60	24	x	M14	195	38 700	431	170	130	6,0	298-002-180
190	250	46	52	68	28	x	M14	195	44 700	502	155	120	8,5	298-002-190
200	260	46	52	68	30	x	M14	195	53 500	538	155	120	8,6	298-002-200



Anzugsmoment | starting torque M_M [Nm]
 Drehmoment | torque M_t [Nm]
 Axialkraft | thrust F_a [kN]
 Flächenpressung - Welle | contact pressure - shaft P_W [N/mm²]
 Flächenpressung - Nabe | contact pressure - hub P_N [N/mm²]

Spannsätze - selbstzentrierend

Locking Assemblies - Self-centering

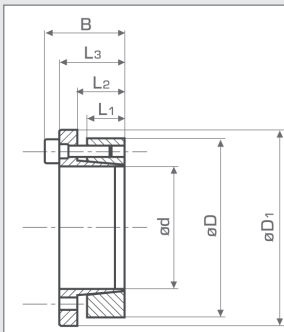

Kennzeichen:

Mittlere bis hohe Drehmomente
Kurze Montagezeiten
Kostengünstige Anwendung
Austauschbar mit WMH-Serie 298-002...

Toleranzen, Rauhtiefe:

Höchste zulässige Rauhtiefe:
Rt max 16 µm (Ra 3 µm - Rz 13 µm)
Wellentoleranz = h 8; Nabentoleranz = H 8

Axiale Verschiebung:

Während des Schraubenanziehens erfolgt keine axiale Verschiebung der Nabe gegenüber der Welle.

Characteristics:

Medium-high torque
Limited installation time
Application economically advantageous
Interchangeable with WMH serie 298-002...

Tolerances, surface finish:

Maximum allowable surface finish:
Rt max 16 µm (Ra 3 µm - Rz 13 µm)
Shaft tolerance = h 8; hub tolerance = H 8

Axial movement:

During screws tightening the hub has no axial movement with respect to the shaft.

d	D	L ₁	L ₂	L ₃	B	D ₁	Spannschrauben				M _M	M _t	F _a	P _W	P _N	[kg]	Bestell Nr.
							Set screws										Part No.
20	47	17	22	28	34	54	5	x	M6	17	280	28	220	95	0,3	298-004-020	
22	47	17	22	28	34	54	5	x	M6	17	300	28	200	95	0,3	298-004-022	
24	50	17	22	28	34	57	5	x	M6	17	330	28	180	90	0,3	298-004-024	
25	50	17	22	28	34	57	6	x	M6	17	420	34	210	105	0,3	298-004-025	
28	55	17	22	28	34	62	6	x	M6	17	470	34	190	95	0,4	298-004-028	
30	55	17	22	28	34	62	6	x	M6	17	500	34	175	95	0,4	298-004-030	
32	60	17	22	28	34	67	8	x	M6	17	720	45	220	115	0,4	298-004-032	
35	60	17	22	28	34	67	8	x	M6	17	790	45	200	115	0,4	298-004-035	
38	65	17	22	28	34	72	8	x	M6	17	850	45	185	105	0,5	298-004-038	
40	65	17	22	28	34	72	8	x	M6	17	900	45	175	105	0,5	298-004-040	
42	75	20	25	33	41	82	7	x	M8	41	1 530	73	225	125	0,8	298-004-042	
45	75	20	25	33	41	82	7	x	M8	41	1 650	73	215	125	0,7	298-004-045	
48	80	20	25	33	41	87	7	x	M8	41	1 760	73	200	120	0,8	298-004-048	
50	80	20	25	33	41	87	7	x	M8	41	1 830	73	195	120	0,8	298-004-050	
55	85	20	25	33	41	92	8	x	M8	41	2 300	83	200	130	0,9	298-004-055	
60	90	20	25	33	41	97	8	x	M8	41	2 510	83	185	125	0,9	298-004-060	
65	95	20	25	33	41	102	9	x	M8	41	3 060	94	190	130	1,0	298-004-065	
70	110	24	30	40	50	117	8	x	M10	83	4 670	133	210	135	1,9	298-004-070	
75	115	24	30	40	50	122	8	x	M10	83	5 000	133	195	125	2,0	298-004-075	
80	120	24	30	40	50	127	8	x	M10	83	5 300	133	185	125	2,0	298-004-080	
85	125	24	30	40	50	132	9	x	M10	83	6 300	148	195	135	2,0	298-004-085	
90	130	24	30	40	50	137	9	x	M10	83	6 750	148	185	130	2,2	298-004-090	
95	135	24	30	40	50	142	10	x	M10	83	7 900	166	195	135	2,3	298-004-095	
100	145	26	32	44	56	152	8	x	M12	145	9 700	194	200	140	3,0	298-004-100	
110	155	26	32	44	56	162	8	x	M12	145	10 600	194	180	130	3,2	298-004-110	
120	165	26	32	44	56	172	9	x	M12	145	13 000	216	185	135	3,4	298-004-120	
130	180	34	40	54	64	187	12	x	M12	145	18 900	290	175	125	5,2	298-004-130	
140	190	34	40	54	68	197	9	x	M14	230	20 500	290	165	120	5,4	298-004-140	
150	200	34	40	54	68	207	10	x	M14	230	25 000	333	175	130	5,7	298-004-150	
160	210	34	40	54	68	217	11	x	M14	230	29 000	362	180	135	6,0	298-004-160	
170	225	44	50	64	78	232	12	x	M14	230	34 000	400	140	105	8,3	298-004-170	
180	235	44	50	64	78	242	12	x	M14	230	36 000	400	135	105	8,8	298-004-180	
190	250	44	50	64	78	257	15	x	M14	230	47 500	500	160	120	10,0	298-004-190	
200	260	44	50	64	78	267	15	x	M14	230	50 000	500	150	115	10,5	298-004-200	

Anzugsmoment | starting torque
Drehmoment | torque
Axialkraft | thrust
Flächenpressung - Welle | contact pressure - shaft
Flächenpressung - Nabe | contact pressure - hub

M_M [Nm]
M_t [Nm]
F_a [kN]
P_W [N/mm²]
P_N [N/mm²]

Spannsätze - selbstzentrierend

Locking Assemblies - Self-centering

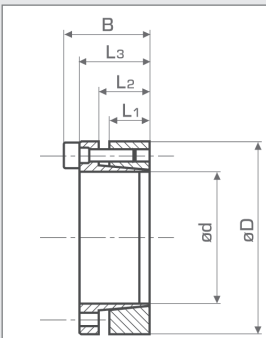

Kennzeichen:
Mittlere bis hohe Drehmomente
Kurze Montagezeiten
Kostengünstige Anwendung
Austauschbar mit WMH-Serie 298-002...

Toleranzen, Rauhtiefe:
Höchste zulässige Rauhtiefe:
Rt max 16 µm (Ra 3 µm - Rz 13 µm)
Wellentoleranz = h 8; Nabentoleranz = H 8

Axiale Verschiebung:
Während des Schraubenanziehens erfolgt eine leichte axiale Verschiebung der Nabe gegenüber der Welle.

Characteristics:
Medium-high torque
Limited installation time
Application economically advantageous
Interchangeable with WMH serie 298-002...

Tolerances, surface finish:
Maximum allowable surface finish:
Rt max 16 µm (Ra 3 µm - Rz 13 µm)
Shaft tolerance = h 8; hub tolerance = H 8

Axial movement:
During screws tightening the hub has a slight axial movement with respect to the shaft.

d	D	L ₁	L ₂	L ₃	B	Spannschrauben				M _M	M _t	F _a	P _W	P _N	[kg]	Bestell Nr.
						Set screws	x									Part No.
20	47	17	22	28	34	5	x	M6	14	380	38	295	125	0,3	298-005-020	
22	47	17	22	28	34	5	x	M6	14	410	38	270	125	0,3	298-005-022	
24	50	17	22	28	34	5	x	M6	14	450	38	245	120	0,3	298-005-024	
25	50	17	22	28	34	6	x	M6	14	570	46	285	140	0,3	298-005-025	
28	55	17	22	28	34	6	x	M6	14	630	46	255	130	0,4	298-005-028	
30	55	17	22	28	34	6	x	M6	14	660	46	235	130	0,3	298-005-030	
32	60	17	22	28	34	8	x	M6	14	970	60	295	155	0,4	298-005-032	
35	60	17	22	28	34	8	x	M6	14	1 060	60	270	155	0,4	298-005-035	
38	65	17	22	28	34	8	x	M6	14	1 150	60	250	145	0,4	298-005-038	
40	65	17	22	28	34	8	x	M6	14	1 210	60	235	145	0,4	298-005-040	
42	75	20	25	33	41	7	x	M8	35	2 050	98	300	170	0,8	298-005-042	
45	75	20	25	33	41	7	x	M8	35	2 200	98	290	170	0,6	298-005-045	
48	80	20	25	33	41	7	x	M8	35	2 350	98	270	160	0,8	298-005-048	
50	80	20	25	33	41	7	x	M8	35	2 450	98	260	160	0,8	298-005-050	
55	85	20	25	33	41	8	x	M8	35	3 080	112	270	175	0,8	298-005-055	
60	90	20	25	33	41	8	x	M8	35	3 360	112	245	165	0,8	298-005-060	
65	95	20	25	33	41	9	x	M8	35	4 090	126	255	175	0,9	298-005-065	
70	110	24	30	40	50	8	x	M10	70	6 300	179	280	180	1,8	298-005-070	
75	115	24	30	40	50	8	x	M10	70	6 700	179	260	170	1,8	298-005-075	
80	120	24	30	40	50	8	x	M10	70	7 150	179	250	170	1,8	298-005-080	
85	125	24	30	40	50	9	x	M10	70	8 500	200	260	180	2,0	298-005-085	
90	130	24	30	40	50	9	x	M10	70	9 100	200	250	170	2,1	298-005-090	
95	135	24	30	40	50	10	x	M10	70	10 600	224	260	180	2,1	298-005-095	
100	145	26	32	44	56	8	x	M12	125	13 400	268	270	190	2,8	298-005-100	
110	155	26	32	44	56	8	x	M12	125	14 600	268	240	180	3,0	298-005-110	
120	165	26	32	44	56	9	x	M12	125	17 900	298	250	180	3,2	298-005-120	
130	180	34	40	54	64	12	x	M12	125	26 000	400	240	170	4,8	298-005-130	
140	190	34	40	54	68	9	x	M14	190	27 000	384	210	150	5,2	298-005-140	
150	200	34	40	54	68	10	x	M14	190	33 000	440	230	170	5,4	298-005-150	
160	210	34	40	54	68	11	x	M14	190	38 000	479	230	170	5,7	298-005-160	
170	225	44	50	64	78	12	x	M14	190	45 000	530	180	130	8,0	298-005-170	
180	235	44	50	64	78	12	x	M14	190	47 000	530	170	130	8,3	298-005-180	
190	250	44	50	64	78	15	x	M14	190	62 900	660	210	150	9,6	298-005-190	
200	260	44	50	64	78	15	x	M14	190	66 000	660	190	150	10,0	298-005-200	



Anzugsmoment starting torque	M _M	[Nm]
Drehmoment torque	M _t	[Nm]
Axialkraft thrust	F _a	[kN]
Flächenpressung - Welle contact pressure - shaft	P _W	[N/mm ²]
Flächenpressung - Nabe contact pressure - hub	P _N	[N/mm ²]

Spannsätze - selbstzentrierend Locking Assemblies - Self-centering

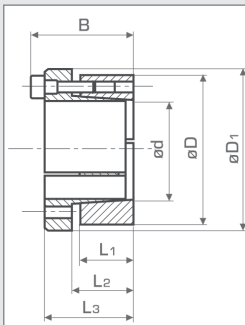

Kennzeichen:
Hohe Drehmomente
Kurze Montagezeiten
Kostengünstige Anwendung

Toleranzen, Rauhtiefe:
Höchste zulässige Rauhtiefe:
Rt max 16 µm (Ra 3 µm - Rz 13 µm)
Wellentoleranz = h 8; Nabentoleranz = H 8

Axiale Verschiebung:
Während des Schraubenanziehens erfolgt keine axiale Verschiebung der Nabe gegenüber der Welle.

Characteristics:
High torque
Limited installation time
Application economically advantageous

Tolerances, surface finish:
Maximum allowable surface finish:
Rt max 16 µm (Ra 3 µm - Rz 13 µm)
Shaft tolerance = h 8; hub tolerance = H 8

Axial movement:
During screws tightening the hub has no axial movement with respect to the shaft.

d	D	L ₁	L ₂	L ₃	B	D ₁	Spannschrauben			M _M	M _t	F _a	P _W	P _N	[kg]	Bestell Nr.
							Set screws									Part No.
20	47	26	30	41	47	53	6	x	M6	17	330	34	175	75	0,5	298-006-020
22	47	26	30	41	47	53	6	x	M6	17	370	34	160	75	0,5	298-006-022
24	50	26	30	41	47	56	6	x	M6	17	400	34	145	70	0,5	298-006-024
25	50	26	30	41	47	56	6	x	M6	17	420	34	140	70	0,5	298-006-025
28	55	26	30	41	47	61	6	x	M6	17	470	34	125	65	0,6	298-006-028
30	55	26	30	41	47	61	6	x	M6	17	510	34	115	65	0,6	298-006-030
32	60	26	30	41	47	66	9	x	M6	17	720	45	145	80	0,7	298-006-032
35	60	26	30	41	47	66	9	x	M6	17	790	45	135	80	0,6	298-006-035
38	65	26	30	41	47	71	9	x	M6	17	860	45	125	70	0,8	298-006-038
40	65	26	30	41	47	71	9	x	M6	17	900	45	120	70	0,6	298-006-040
42	75	30	35	49	57	81	6	x	M8	41	1 320	63	135	75	1,2	298-006-042
45	75	30	35	49	57	81	6	x	M8	41	1 410	63	125	75	1,1	298-006-045
48	80	30	35	49	57	86	6	x	M8	41	1 510	63	120	70	1,3	298-006-048
50	80	30	35	49	57	86	6	x	M8	41	1 570	63	110	70	1,1	298-006-050
55	85	30	35	49	57	91	9	x	M8	41	2 310	84	135	90	1,2	298-006-055
60	90	30	35	49	57	96	9	x	M8	41	2 520	84	124	85	1,3	298-006-060
65	95	30	35	49	57	102	9	x	M8	41	2 730	84	115	80	1,4	298-006-065
70	110	40	45	59	69	117	7	x	M10	83	4 650	133	125	80	2,5	298-006-070
75	115	40	45	59	69	122	7	x	M10	83	5 000	133	120	80	2,6	298-006-075
80	120	40	45	59	69	127	7	x	M10	83	5 330	133	110	75	2,8	298-006-080
85	125	40	45	59	69	132	8	x	M10	83	7 080	167	130	90	2,8	298-006-085
90	130	40	45	59	69	137	8	x	M10	83	7 500	167	125	85	3,0	298-006-090
95	135	40	45	59	69	142	10	x	M10	83	7 900	167	115	85	3,0	298-006-095
100	145	46	52	68	80	153	7	x	M12	145	9 700	194	115	80	5,5	298-006-100
110	155	46	52	68	80	163	7	x	M12	145	10 650	194	100	75	4,8	298-006-110
120	165	46	52	68	80	173	8	x	M12	145	14 550	243	120	85	5,5	298-006-120
130	180	46	52	68	80	188	10	x	M12	145	18 950	291	130	95	6,0	298-006-130
140	190	50	57	76	90	199	11	x	M14	230	18 650	267	100	75	7,5	298-006-140
150	200	50	57	76	90	209	12	x	M14	230	25 000	333	120	90	7,7	298-006-150
160	210	50	57	76	90	219	13	x	M14	230	26 650	333	110	85	8,0	298-006-160
170	225	50	57	76	90	234	14	x	M14	230	34 000	400	125	95	9,8	298-006-170
180	235	50	57	76	90	244	14	x	M14	230	36 000	400	120	90	9,8	298-006-180

Anzugsmoment | starting torque
Drehmoment | torque
Axialkraft | thrust
Flächenpressung - Welle | contact pressure - shaft
Flächenpressung - Nabe | contact pressure - hub

M_M [Nm]
M_t [Nm]
F_a [kN]
P_W [N/mm²]
P_N [N/mm²]

Spannsätze - selbstzentrierend

Locking Assemblies - Self-centering

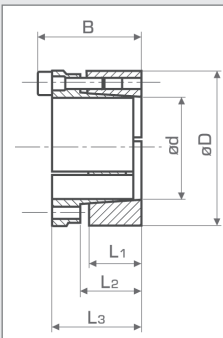

Kennzeichen:
Hohe Drehmomente
Kurze Montagezeiten
Kostengünstige Anwendung

Toleranzen, Rauhtiefe:
Höchste zulässige Rauhtiefe:
Rt max 16 µm (Ra 3 µm - Rz 13 µm)
Wellentoleranz = h 8; Nabentoleranz = H 8

Axiale Verschiebung:
Während des Schraubenanziehens erfolgt eine leichte axiale Verschiebung der Nabe gegenüber der Welle.

Characteristics:
High torque
Limited installation time
Application economically advantageous

Tolerances, surface finish:
Maximum allowable surface finish:
Rt max 16 µm (Ra 3 µm - Rz 13 µm)
Shaft tolerance = h 8; hub tolerance = H 8

Axial movement:
During screws tightening the hub has a slight axial movement with respect to the shaft.

d	D	L ₁	L ₂	L ₃	B	Spannschrauben				M _M	M _t	F _a	P _W	P _N	[kg]	Bestell Nr.
						Set screws	x	M								Part No.
20	47	26	30	41	47	6	x	M6	17	540	54	280	120	0,4	298-007-020	
22	47	26	30	41	47	6	x	M6	17	600	54	255	120	0,4	298-007-022	
24	50	26	30	41	47	6	x	M6	17	650	54	235	115	0,4	298-007-024	
25	50	26	30	41	47	6	x	M6	17	680	54	225	115	0,4	298-007-025	
28	55	26	30	41	47	6	x	M6	17	760	54	200	105	0,5	298-007-028	
30	55	26	30	41	47	6	x	M6	17	820	54	185	105	0,5	298-007-030	
32	60	26	30	41	47	9	x	M6	17	1 160	73	235	125	0,6	298-007-032	
35	60	26	30	41	47	9	x	M6	17	1 270	73	215	125	0,5	298-007-035	
38	65	26	30	41	47	9	x	M6	17	1 380	73	200	115	0,6	298-007-038	
40	65	26	30	41	47	9	x	M6	17	1 450	73	190	115	0,6	298-007-040	
42	75	30	35	49	57	6	x	M8	41	2 130	101	215	120	1,0	298-007-042	
45	75	30	35	49	57	6	x	M8	41	2 280	101	200	120	1,0	298-007-045	
48	80	30	35	49	57	6	x	M8	41	2 430	101	190	115	1,1	298-007-048	
50	80	30	35	49	57	6	x	M8	41	2 530	101	180	115	1,0	298-007-050	
55	85	30	35	49	57	9	x	M8	41	3 700	135	220	140	1,1	298-007-055	
60	90	30	35	49	57	9	x	M8	41	4 000	135	200	135	1,2	298-007-060	
65	95	30	35	49	57	9	x	M8	41	4 380	135	185	125	1,3	298-007-065	
70	110	40	45	59	69	7	x	M10	83	7 500	214	205	130	2,2	298-007-070	
75	115	40	45	59	69	7	x	M10	83	8 000	214	190	125	2,5	298-007-075	
80	120	40	45	59	69	7	x	M10	83	8 560	214	180	120	2,6	298-007-080	
85	125	40	45	59	69	8	x	M10	83	11 370	268	210	145	2,8	298-007-085	
90	130	40	45	59	69	8	x	M10	83	12 000	268	200	135	2,7	298-007-090	
95	135	40	45	59	69	10	x	M10	83	12 600	268	190	130	2,9	298-007-095	
100	145	46	52	68	80	7	x	M12	145	15 580	312	180	125	3,9	298-007-100	
110	155	46	52	68	80	7	x	M12	145	17 100	312	165	115	4,2	298-007-110	
120	165	46	52	68	80	8	x	M12	145	23 370	390	190	135	4,8	298-007-120	
130	180	46	52	68	80	10	x	M12	145	30 380	467	210	150	5,0	298-007-130	
140	190	50	57	76	90	11	x	M14	230	29 900	428	165	120	6,5	298-007-140	
150	200	50	57	76	90	12	x	M14	230	40 000	535	190	145	7,0	298-007-150	
160	210	50	57	76	90	13	x	M14	230	42 750	535	180	135	7,0	298-007-160	
170	225	50	57	76	90	14	x	M14	230	54 500	641	200	150	8,5	298-007-170	
180	235	50	57	76	90	14	x	M14	230	57 700	641	190	145	9,0	298-007-180	



Anzugsmoment starting torque	M _M	[Nm]
Drehmoment torque	M _t	[Nm]
Axialkraft thrust	F _a	[kN]
Flächenpressung - Welle contact pressure - shaft	P _W	[N/mm ²]
Flächenpressung - Nabe contact pressure - hub	P _N	[N/mm ²]

Spannsätze - selbstzentrierend

Locking Assemblies - Self-centering

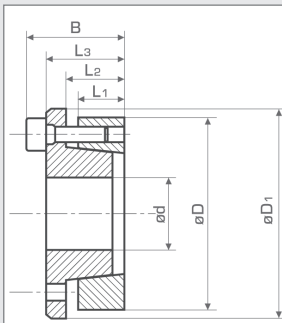

Kennzeichen:

Mittlere bis hohe Drehmomente
Kurze Montagezeiten
Kostengünstige Anwendung
Austauschbar mit WMH-Serie 298-002...

Toleranzen, Rauhtiefe:

Höchste zulässige Rauhtiefe:
Rt max 16 µm (Ra 3 µm - Rz 13 µm)
Wellentoleranz = h 8; Nabentoleranz = H 8

Axiale Verschiebung:

Während des Schraubenanziehens erfolgt keine axiale Verschiebung der Nabe gegenüber der Welle.

Characteristics:

Medium-high torque
Limited installation time
Application economically advantageous
Interchangeable with WMH serie 298-002...

Tolerances, surface finish:

Maximum allowable surface finish:
Rt max 16 µm (Ra 3 µm - Rz 13 µm)
Shaft tolerance = h 8; hub tolerance = H 8

Axial movement:

During screws tightening the hub has no axial movement with respect to the shaft.

d	D	L ₁	L ₂	L ₃	B	D ₁	Spannschrauben				M _M	M _t	F _a	P _W	P _N	[kg]	Bestell Nr.
							Set screws										Part No.
14	55	17	22	30	38	62	3	x	M8	25	120	18	205	55	0,5	298-008-012	
16	55	17	22	30	38	62	3	x	M8	25	140	18	180	55	0,5	298-008-014	
18	55	17	22	30	38	62	3	x	M8	25	150	18	160	55	0,5	298-008-015	
19	55	17	22	30	38	62	3	x	M8	25	160	18	150	55	0,5	298-008-016	
20	55	17	22	30	38	62	3	x	M8	25	170	18	145	55	0,5	298-008-017	
22	55	17	22	30	38	62	3	x	M8	35	280	25	185	75	0,5	298-008-028	
24	55	17	22	30	38	62	3	x	M8	35	300	25	170	75	0,5	298-008-030	
25	55	17	22	30	38	62	3	x	M8	35	310	25	165	75	0,5	298-008-031	
28	55	17	22	30	38	62	3	x	M8	41	430	31	175	90	0,4	298-008-043	
30	55	17	22	30	38	62	3	x	M8	41	470	31	165	90	0,4	298-008-047	
24	65	17	22	30	38	72	5	x	M8	30	440	37	244	90	0,7	298-008-044	
25	65	17	22	30	38	72	5	x	M8	30	460	37	234	90	0,7	298-008-046	
28	65	17	22	30	38	72	5	x	M8	35	600	44	243	105	0,6	298-008-060	
30	65	17	22	30	38	72	5	x	M8	35	640	44	227	105	0,6	298-008-064	
32	65	17	22	30	38	72	5	x	M8	35	690	44	213	105	0,6	298-008-069	
35	65	17	22	30	38	72	5	x	M8	41	910	52	234	126	0,5	298-008-091	
38	65	17	22	30	38	72	5	x	M8	41	990	52	216	126	0,5	298-008-099	
40	65	17	22	30	38	72	5	x	M8	41	1 050	52	205	126	0,5	298-008-105	
30	80	20	25	33	41	87	7	x	M8	30	780	52	232	87	1,0	298-008-078	
32	80	20	25	33	41	87	7	x	M8	30	830	52	217	87	1,0	298-008-083	
35	80	20	25	33	41	87	7	x	M8	35	1 060	61	232	102	1,0	298-008-106	
38	80	20	25	33	41	87	7	x	M8	35	1 150	61	214	102	1,0	298-008-115	
40	80	20	25	33	41	87	7	x	M8	35	1 220	61	203	102	0,9	298-008-122	
42	80	20	25	33	41	87	7	x	M8	41	1 540	73	233	122	0,9	298-008-157	
45	80	20	25	33	41	87	7	x	M8	41	1 650	73	217	122	0,8	298-008-165	
48	80	20	25	33	41	87	7	x	M8	41	1 760	73	203	122	0,8	298-008-176	
50	80	20	25	33	41	87	7	x	M8	41	1 830	73	195	122	0,8	298-008-183	

Anzugsmoment | starting torque
Drehmoment | torque
Axialkraft | thrust
Flächenpressung - Welle | contact pressure - shaft
Flächenpressung - Nabe | contact pressure - hub

M_M [Nm]
M_t [Nm]
F_a [kN]
P_W [N/mm²]
P_N [N/mm²]

Spannsätze - Berechnung des Nabenmindstdurchmessers DM

Locking Assemblies - Calculation of Minimum Hub Diameter DM

Nachfolgende Erläuterungen und Tabellen beziehen sich auf folgende WMH-Spannsatz-Serien:
The following explanations and tables refer to these WMH locking assemblies:

298-001-...	298-006-...
298-002-...	298-007-...
298-004-...	298-008-...
298-005-...	

Bei der Anwendung von Spannsätzen erzeugt die Flächenpressung P_N zwischen Spannsatz- Außendurchmesser und Nabe eine Spannung. Für die Berechnung des Nabenmindstdurchmessers DM wird die selbe Formel benutzt wie für die dicken Hohlzylinder. Abhängig von den Nabenlängen und -formen gegenüber der Länge L_1 des Spannsatzes ändern sich die realen Spannungen.

By installing locking assemblies, the surface pressure P_N , existing between the clamping outer ring and related hub bore, generate a stress. To calculate the minimum hub diameter DM the formula normally used for thick hollow cylinder is valid. Depending from hub shape and length with respect to the dimension L_1 of locking assemblies, the real stresses change.

Der Faktor C ist in Funktion vom Anwendungstyp zu berücksichtigen.

Factor C must be considered in function of application type.

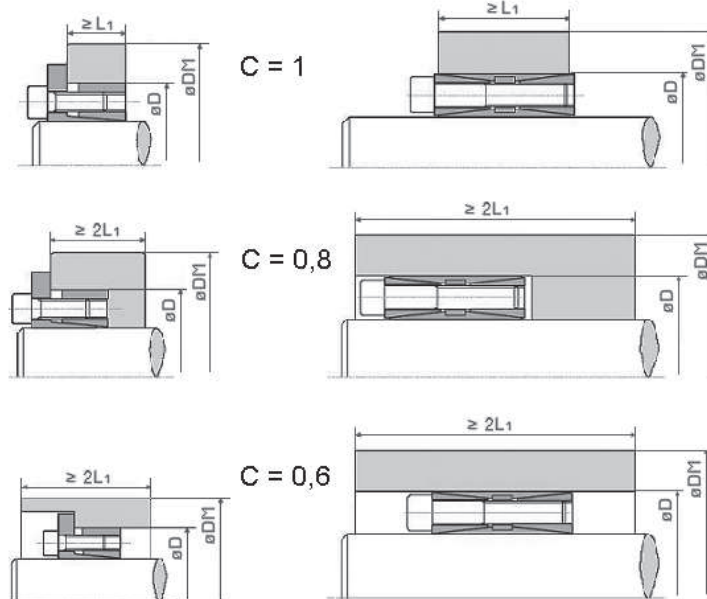

Für die Berechnung vom Nabenmindstdurchmesser DM muss man folgende Formel anwenden: $DM = D \cdot K$, wobei K gleich:

For minimum hub diameter DM calculation following formula must be applied: $DM = D \cdot K$, where K is equal to:

$$K = \sqrt{\frac{s_{02} + (C \cdot P_N)}{s_{02} - (C \cdot P_N)}}$$

Um die Berechnungen einfacher zu machen, wurde die Tabelle des Koeffizienten K auf Seite K 15 erarbeitet.

To simplify the calculation we prepared the table of coefficient K (see page K 15).

Beispiel:

WMH Spannsatz 298-006-060 \varnothing 60 x 90
Nabenpressung $P_N = 85 \text{ N/mm}^2$ (siehe Tabelle auf Seite K 11).
Nabenwerkstoff GGG40 (Streckgrenze = 250 N/mm^2).
Nabenbreite und -form entsprechend $C = 1$.
 $DM = 90 \cdot 1,42 = 127,8 \text{ mm}$

Example:

WMH locking assembly type 298-006-060 \varnothing 60 x 90
Hub pressure $P_N = 85 \text{ N/mm}^2$ (see page K 11).
Hub material GGG40 (yielding limit = 250 N/mm^2).
Hub length and shape equivalent $C = 1$.
 $DM = 90 \cdot 1,42 = 127,8 \text{ mm}$

Spannsätze - Berechnung des Nabenmindstdurchmessers DM

Locking Assemblies - Calculation of Minimum Hub Diameter DM

Tabelle des Koeffizienten K

table of coefficient K

Nabenpressung Pressure generated on the hub		σ_{02} Streckgrenze yield point [N/mm ²]										
		150	180	200	220	250	270	300	350	400	450	600
P _N [N/mm ²]	Anwendungstyp Application type C	Werkstofftyp material type										
		GG20	GG25 GS38	GG30 GTS35	GS45 St 37-2	GGG40 GS52	St 50-2 C35	GGG50 GS60 St60-2	GGG60 GS62 St 70-2	GGG70 GS70 C60		
60	C = 0,6	1,28	1,25	1,20	1,18	1,15	1,14	1,12	1,10	1,09	1,08	1,06
	C = 0,8	1,39	1,30	1,24	1,23	1,22	1,20	1,18	1,15	1,12	1,11	1,08
	C = 1	1,52	1,42	1,36	1,32	1,28	1,25	1,22	1,18	1,16	1,14	1,10
65	C = 0,6	1,30	1,25	1,22	1,20	1,18	1,15	1,13	1,11	1,10	1,09	1,07
	C = 0,8	1,44	1,35	1,30	1,28	1,24	1,22	1,20	1,16	1,14	1,12	1,09
	C = 1	1,60	1,45	1,40	1,35	1,30	1,28	1,24	1,20	1,18	1,16	1,12
70	C = 0,6	1,34	1,26	1,24	1,22	1,18	1,16	1,15	1,12	1,11	1,10	1,07
	C = 0,8	1,48	1,38	1,34	1,30	1,25	1,23	1,20	1,18	1,15	1,13	1,10
	C = 1	1,65	1,50	1,45	1,40	1,34	1,30	1,26	1,22	1,20	1,17	1,13
75	C = 0,6	1,30	1,28	1,25	1,23	1,20	1,18	1,16	1,14	1,12	1,11	1,08
	C = 0,8	1,52	1,42	1,36	1,32	1,28	1,25	1,22	1,18	1,16	1,14	1,11
	C = 1	1,74	1,55	1,48	1,42	1,36	1,33	1,30	1,25	1,20	1,18	1,13
80	C = 0,6	1,39	1,31	1,28	1,25	1,21	1,20	1,18	1,15	1,13	1,11	1,08
	C = 0,8	1,58	1,45	1,39	1,35	1,30	1,27	1,24	1,20	1,18	1,15	1,11
	C = 1	1,81	1,61	1,53	1,46	1,39	1,36	1,31	1,26	1,22	1,20	1,14
85	C = 0,6	1,42	1,34	1,30	1,27	1,23	1,21	1,19	1,16	1,14	1,12	1,09
	C = 0,8	1,63	1,49	1,42	1,38	1,32	1,29	1,26	1,22	1,19	1,16	1,12
	C = 1	1,90	1,67	1,57	1,50	1,42	1,39	1,34	1,28	1,24	1,21	1,15
90	C = 0,6	1,46	1,36	1,32	1,28	1,25	1,22	1,20	1,17	1,15	1,13	1,09
	C = 0,8	1,69	1,53	1,46	1,40	1,34	1,31	1,28	1,23	1,20	1,18	1,13
	C = 1	2,00	1,73	1,62	1,54	1,46	1,41	1,36	1,30	1,26	1,22	1,16
95	C = 0,6	1,49	1,39	1,34	1,30	1,26	1,24	1,21	1,18	1,15	1,14	1,10
	C = 0,8	1,75	1,57	1,49	1,43	1,37	1,34	1,30	1,25	1,21	1,19	1,14
	C = 1	2,11	1,80	1,68	1,59	1,49	1,44	1,39	1,32	1,27	1,24	1,17
100	C = 0,6	1,53	1,41	1,36	1,32	1,28	1,25	1,22	1,19	1,16	1,14	1,11
	C = 0,8	1,81	1,61	1,53	1,46	1,39	1,36	1,31	1,26	1,22	1,20	1,14
	C = 1	2,24	1,87	1,73	1,63	1,53	1,48	1,41	1,34	1,29	1,25	1,18
105	C = 0,6	1,56	1,44	1,39	1,34	1,29	1,27	1,24	1,20	1,17	1,15	1,11
	C = 0,8	1,88	1,66	1,56	1,50	1,42	1,38	1,33	1,28	1,24	1,21	1,15
	C = 1	2,38	1,95	1,79	1,68	1,56	1,51	1,44	1,36	1,31	1,27	1,19
110	C = 0,6	1,60	1,47	1,41	1,36	1,31	1,28	1,25	1,21	1,18	1,16	1,12
	C = 0,8	1,96	1,71	1,60	1,53	1,44	1,41	1,35	1,29	1,25	1,22	1,16
	C = 1	2,55	2,04	1,86	1,73	1,60	1,54	1,47	1,38	1,33	1,28	1,20
115	C = 0,6	1,64	1,50	1,43	1,36	1,33	1,30	1,26	1,22	1,19	1,17	1,12
	C = 0,8	2,04	1,76	1,64	1,56	1,47	1,43	1,37	1,31	1,26	1,23	1,17
	C = 1	2,75	2,13	1,93	1,79	1,64	1,58	1,50	1,41	1,34	1,30	1,21
120	C = 0,6	1,69	1,53	1,46	1,40	1,34	1,31	1,28	1,23	1,20	1,18	1,13
	C = 0,8	2,13	1,81	1,69	1,60	1,50	1,45	1,39	1,33	1,28	1,24	1,18
	C = 1	3,00	2,24	2,00	1,84	1,69	1,61	1,53	1,43	1,36	1,31	1,22
125	C = 0,6	1,73	1,56	1,48	1,43	1,36	1,33	1,29	1,24	1,21	1,18	1,13
	C = 0,8	2,24	1,87	1,73	1,63	1,53	1,48	1,41	1,34	1,29	1,25	1,18
	C = 1	3,32	2,35	2,08	1,91	1,73	1,65	1,56	1,45	1,38	1,33	1,24
130	C = 0,6	1,78	1,59	1,51	1,45	1,38	1,35	1,30	1,25	1,22	1,19	1,14
	C = 0,8	2,35	1,93	1,78	1,67	1,56	1,50	1,44	1,36	1,30	1,27	1,19
	C = 1	3,74	2,49	2,17	1,97	1,78	1,69	1,59	1,48	1,40	1,35	1,25
135	C = 0,6	1,83	1,62	1,54	1,47	1,40	1,36	1,32	1,27	1,23	1,20	1,15
	C = 0,8	2,48	2,00	1,83	1,71	1,59	1,53	1,46	1,38	1,32	1,28	1,20
	C = 1	4,36	2,65	2,27	2,04	1,83	1,73	1,62	1,50	1,42	1,36	1,26
140	C = 0,6	1,88	1,66	1,56	1,50	1,42	1,38	1,33	1,28	1,24	1,21	1,15
	C = 0,8	2,63	2,07	1,88	1,75	1,62	1,55	1,48	1,39	1,33	1,29	1,21
	C = 1	5,39	2,83	2,38	2,12	1,88	1,78	1,66	1,53	1,44	1,38	1,27
145	C = 0,6	1,94	1,69	1,59	1,52	1,44	1,40	1,35	1,29	1,25	1,22	1,16
	C = 0,8	2,80	2,15	1,94	1,80	1,65	1,58	1,50	1,41	1,35	1,30	1,22
	C = 1	7,68	3,05	2,50	2,21	1,94	1,82	1,69	1,55	1,46	1,40	1,28
150	C = 0,6	2,00	1,73	1,62	1,54	1,46	1,41	1,36	1,30	1,26	1,23	1,16
	C = 0,8	3,00	2,24	2,00	1,84	1,69	1,61	1,53	1,43	1,36	1,31	1,23
	C = 1	-	3,32	2,65	2,30	2,00	1,87	1,73	1,58	1,48	1,41	1,29
155	C = 0,6	2,06	1,77	1,65	1,57	1,48	1,43	1,38	1,31	1,27	1,24	1,17
	C = 0,8	3,25	2,33	2,06	1,89	1,72	1,65	1,55	1,45	1,38	1,33	1,23
	C = 1	-	3,66	2,80	2,40	2,06	1,92	1,77	1,61	1,51	1,43	1,30
160	C = 0,6	2,13	1,81	1,69	1,60	1,50	1,45	1,39	1,33	1,28	1,24	1,18
	C = 0,8	3,55	2,43	2,13	1,94	1,76	1,67	1,58	1,47	1,39	1,34	1,24
	C = 1	-	4,12	3,00	2,52	2,13	1,98	1,81	1,64	1,53	1,45	1,31
165	C = 0,6	2,21	1,86	1,72	1,62	1,52	1,47	1,41	1,34	1,29	1,25	1,18
	C = 0,8	3,96	2,55	2,21	2,00	1,80	1,71	1,60	1,49	1,41	1,35	1,25
	C = 1	-	4,80	3,23	2,65	2,21	2,04	1,86	1,67	1,55	1,47	1,33

Schrumpfscheiben Shrink Discs

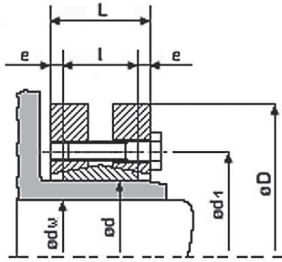

Kennzeichen:
Hohe bis höchste Drehmomente
Kurze Montagezeiten
Schnelle Demontage
Keine axiale Verschiebung Welle - Nabe

Toleranzen, Rauhtiefe:
Höchste zulässige Rauhtiefe:
Rt max 16 µm (Ra 3 µm - Rz 13 µm)
Höchste zulässige Wellentoleranz = h 8

Nabentoleranz: Naben-Ø 18 bis 30 mm = H6/j6
Naben-Ø 30 bis 50 mm = H6/h6
Naben-Ø 50 bis 80 mm = H6/g6
Naben-Ø 80 bis 500 mm = H7/g6

Axiale Verschiebung:
Während des Schraubenanziehens erfolgt keine axiale Verschiebung der Nabe gegenüber der Welle.

Characteristics:
Medium-high torque
Limited installation time
Quick dismantling
No shaft-hub axial movement

Tolerances, surface finish:
Maximum allowable surface finish:
Rt max 16 µm (Ra 3 µm - Rz 13 µm)
Maximum permissible shaft tolerance = h 8

Hub tolerance: hub Ø 18 to 30 mm = H6/j6
hub Ø 30 to 50 mm = H6/h6
hub Ø 50 to 80 mm = H6/g6
hub Ø 80 to 500 mm = H7/g6

Axial movement:
During screws tightening the hub has no axial movement with respect to the shaft.

d	d _w	D	l	L	d ₁	e	Spannschrauben			M _M	M _t	F _a	[kg]	Bestell Nr.
							Set screws							Part No.
30	24	60	16	21,5	44	2,75	7	x	M5	4	300	29	0,3	298-101-130
30	25	60	16	21,5	44	2,75	7	x	M5	4	340	31	0,3	298-101-230
30	26	60	16	21,5	44	2,75	7	x	M5	4	380	33	0,3	298-101-330
36	28	72	18	23,5	52	2,75	5	x	M6	12	440	50	0,4	298-101-136
36	30	72	18	23,5	52	2,75	5	x	M6	12	570	58	0,4	298-101-236
36	31	72	18	23,5	52	2,75	5	x	M6	12	630	58	0,4	298-101-336
44	32	80	20	25,5	61	2,75	7	x	M6	12	620	64	0,6	298-101-144
44	35	80	20	25,5	61	2,75	7	x	M6	12	780	74	0,6	298-101-244
44	36	80	20	25,5	61	2,75	7	x	M6	12	860	77	0,6	298-101-344
50	38	90	22	27,5	70	2,75	8	x	M6	12	940	79	0,8	298-101-150
50	40	90	22	27,5	70	2,75	8	x	M6	12	1 160	86	0,8	298-101-250
50	42	90	22	27,5	70	2,75	8	x	M6	12	1 380	92	0,8	298-101-350
55	42	100	23	30,5	75	3,75	8	x	M6	12	1 160	79	1,1	298-101-155
55	45	100	23	30,5	75	3,75	8	x	M6	12	1 520	88	1,1	298-101-255
55	48	100	23	30,5	75	3,75	8	x	M6	12	1 880	97	1,1	298-101-355
62	48	110	23	30,5	86	3,75	10	x	M6	12	1 850	100	1,3	298-101-162
62	50	110	23	30,5	86	3,75	10	x	M6	12	2 200	111	1,3	298-101-262
62	52	110	23	30,5	86	3,75	10	x	M6	12	2 400	117	1,3	298-101-362
68	50	115	23	30,5	86	3,75	10	x	M6	12	2 000	97	1,4	298-101-168
68	55	115	23	30,5	86	3,75	10	x	M6	12	2 500	106	1,4	298-101-268
68	60	115	23	30,5	86	3,75	10	x	M6	12	3 150	120	1,4	298-101-368
75	55	138	25	32,5	100	3,75	7	x	M8	30	2 500	119	1,7	298-101-175
75	60	138	25	32,5	100	3,75	7	x	M8	30	3 200	137	1,7	298-101-275
75	65	138	25	32,5	100	3,75	7	x	M8	30	3 950	155	1,7	298-101-375
80	60	145	25	32,5	100	3,75	7	x	M8	30	3 200	124	1,9	298-101-180
80	65	145	25	32,5	100	3,75	7	x	M8	30	3 900	140	1,9	298-101-280
80	70	145	25	32,5	100	3,75	7	x	M8	30	4 600	158	1,9	298-101-380
85	65	155	30	39,0	114	4,50	10	x	M8	30	4 800	175	3,5	298-101-185
85	70	155	30	39,0	114	4,50	10	x	M8	30	6 100	195	3,5	298-101-285
85	75	155	30	39,0	114	4,50	10	x	M8	30	7 400	216	3,5	298-101-385
90	65	155	30	39,0	114	4,50	10	x	M8	30	4 750	170	3,3	298-101-190
90	70	155	30	39,0	114	4,50	10	x	M8	30	6 000	190	3,3	298-101-290
90	75	155	30	39,0	114	4,50	10	x	M8	30	7 250	210	3,3	298-101-390
100	70	170	34	44,0	124	5,00	12	x	M8	30	6 900	195	4,7	298-101-100
100	75	170	34	44,0	124	5,00	12	x	M8	30	7 500	220	4,7	298-101-200
100	80	170	34	44,0	124	5,00	12	x	M8	30	9 000	240	4,7	298-101-300
110	75	185	39	50,0	136	5,50	9	x	M10	59	7 200	229	5,9	298-101-110
110	80	185	39	50,0	136	5,50	9	x	M10	59	9 000	252	5,9	298-101-210
110	85	185	39	50,0	136	5,50	9	x	M10	59	10 800	262	5,9	298-101-310



Weitere Größen auf Anfrage.
For larger size please contact us.

Anzugsmoment | starting torque
Drehmoment | torque
Axialkraft | thrust

M_M [Nm]
M_t [Nm]
F_a [kN]

Spannsätze Trantorques

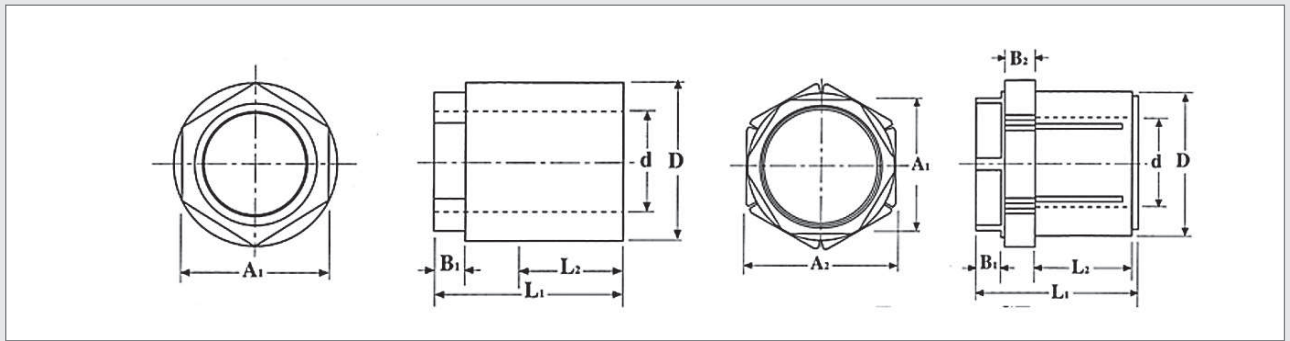

d	D	L ₁	L ₂	A ₁	A ₂	B ₁	B ₂	M _{tmax}	F _{Amax}	P _N	M _A	[kg]	Bestell Nr. Part No.
5	16,0	19,0	10,0	13,0	-	3,0	-	16	6,0	11 200	14	0,02	299-005-000
6	16,0	19,0	10,0	13,0	-	3,0	-	19	6,0	11 200	14	0,02	299-006-000
7	20,0	22,0	11,0	15,9	-	3,0	-	36	10,0	12 300	28	0,03	299-007-000
8	20,0	22,0	11,0	15,9	-	3,0	-	41	10,0	12 300	28	0,03	299-008-000
9	20,0	22,0	11,0	15,9	-	3,0	-	47	10,0	12 300	28	0,03	299-009-000
10	23,0	23,0	13,0	19,0	-	5,0	-	68	14,0	12 300	44	0,05	299-010-000
11	23,0	23,0	13,0	19,0	-	5,0	-	75	14,0	12 300	44	0,05	299-011-000
12	23,0	23,0	13,0	19,0	-	5,0	-	81	14,0	12 300	44	0,05	299-012-000
14	26,0	26,0	16,0	22,0	-	5,0	-	123	18,0	11 300	66	0,06	299-014-000
15	26,0	26,0	16,0	22,0	-	5,0	-	132	18,0	11 300	66	0,06	299-015-000
16	26,0	26,0	16,0	22,0	-	5,0	-	140	18,0	11 300	66	0,06	299-016-000
17	32,0	34,9	19,1	27,0	-	6,4	-	170	8,9	5 500	80	0,06	299-017-000
18	38,0	38,1	19,1	32,0	38,1	8,0	8,9	235	26,0	9 300	136	0,20	299-018-001
19	38,0	38,1	19,1	32,0	38,1	8,0	8,9	248	26,0	9 300	136	0,20	299-019-001
20	45,0	47,6	22,2	38,0	44,5	11,1	9,5	273	27,0	6 400	170	0,40	299-020-001
22	45,0	47,6	22,2	38,0	44,5	11,1	9,5	300	27,0	6 400	170	0,40	299-022-001
24	45,0	47,6	22,2	38,0	44,5	11,1	9,5	327	27,0	6 400	170	0,30	299-024-001
25	45,0	47,6	22,2	38,0	44,5	11,1	9,5	341	27,0	6 400	170	0,30	299-025-001
28	51,0	57,2	25,4	46,0	50,8	12,7	14,3	434	31,0	5 700	225	0,50	299-028-001
30	51,0	57,2	25,4	46,0	50,8	12,7	14,3	465	31,0	5 700	225	0,50	299-030-001
32	51,0	57,2	25,4	46,0	50,8	12,7	14,3	496	31,0	5 700	225	0,50	299-032-001
34	60,5	69,9	38,1	50,0	60,3	14,3	12,7	530	31,0	3 300	260	0,90	299-034-001
35	60,5	69,9	38,1	50,0	60,3	14,3	12,7	546	31,0	3 300	260	0,90	299-035-001
36	60,5	69,9	38,1	50,0	60,3	14,3	12,7	561	31,0	3 300	260	0,90	299-036-001
38	60,5	69,9	38,1	50,0	60,3	14,3	12,7	592	31,0	3 300	260	0,80	299-038-001
40	67,0	79,4	42,9	60,0	66,7	14,3	17,4	679	34,0	2 900	316	1,20	299-040-001
42	67,0	79,4	42,9	60,0	66,7	14,3	17,4	713	34,0	2 900	316	1,10	299-042-001
45	73,0	90,5	50,8	65,0	73,0	15,9	19,1	1 208	54,0	3 600	554	1,60	299-045-001
48	73,0	90,5	50,8	65,0	73,0	15,9	19,1	1 289	54,0	3 600	554	1,60	299-048-001
50	73,0	90,5	50,8	65,0	73,0	15,9	19,1	1 343	54,0	3 600	554	1,50	299-050-001
55	80,0	95,3	54,0	70,0	79,4	15,9	20,7	1 444	53,0	3 100	600	1,80	299-055-001
60	86,0	98,4	57,2	75,0	85,7	17,5	19,1	1 530	51,0	2 600	635	2,00	299-060-001
65	92,0	103,2	60,3	82,0	92,1	17,5	20,7	1 640	50,0	2 300	680	2,00	299-065-001
70	92,0	103,2	60,3	82,0	92,1	17,5	20,7	1 766	50,0	2 300	680	2,00	299-070-001
75	100,0	108,0	63,5	90,0	98,4	19,1	20,7	1 939	52,0	2 100	750	3,00	299-075-001

Wellen und Bohrungstoleranzen:

Bis Größe 299-015-000: ± 0.038 mm

Ab Größe 299-016-000: ± 0.067 mm

Rundlaufgenauigkeit: 0.06 mm

Temperaturbereich - 34° C bis + 200° C

Sämtliche Kontaktflächen müssen sauber und ölfrei sein

Permissible tolerance on shaft and bore:

Up to size 299-015-000: ± 0.038 mm

From size 299-016-000: ± 0.067 mm

Concentricity 0.06 mm

Temperature limits - 34° C to + 200° C

All the surfaces of contact must be clean and free of oil

Drehmoment | max. torque

Max. Axialkraft | max. thrust

Flächenpressung - Nabe | contact pressure on hub

Anzugsmoment der Mutter | installation torque on nut

M_t [Nm]

F_a [kN]

P_N [N/mm²]

M_A [Nm]

Spannsätze Trantorques

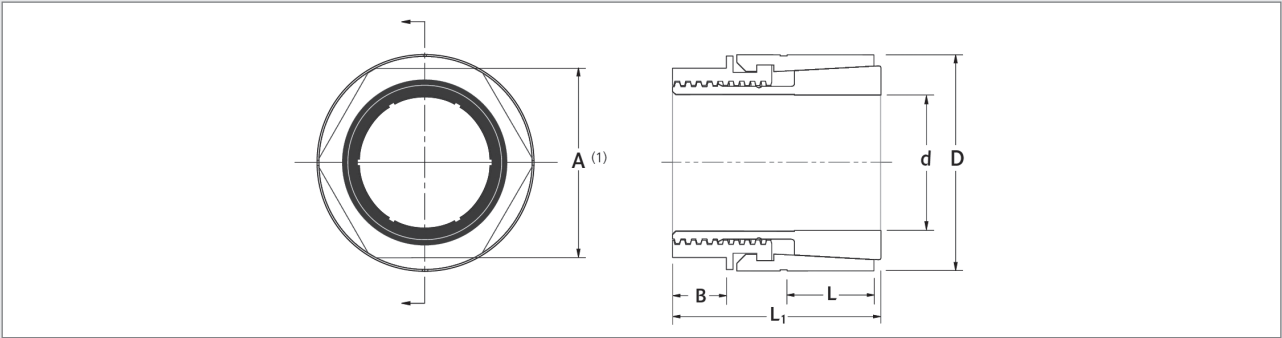

d	D	L	L ₁	A ¹⁾	B	M _{tmax}	F _{Amax}	P _N	M _A	DM ²⁾	[kg]	Bestell Nr. Part No.
15	38,0	19,7	38,1	32,0	8,0	168,0	22,4	79,0	113,0	49,3	0,200	299-015-002
16	38,0	19,7	38,1	32,0	8,0	179,0	22,4	79,0	113,0	49,3	0,200	299-016-002
17	38,0	19,7	38,1	32,0	8,0	190,0	22,4	79,0	113,0	49,3	0,200	299-017-002
18	38,0	19,7	38,1	32,0	8,0	201,0	22,4	79,0	113,0	49,3	0,200	299-018-002
19	38,0	19,7	38,1	32,0	8,0	213,0	22,4	79,0	113,0	49,3	0,200	299-019-002
20	45,0	20,2	42,6	38,0	11,1	233,0	23,3	68,0	141,0	56,2	0,300	299-020-002
22	45,0	20,2	42,6	38,0	11,1	257,0	23,3	68,0	141,0	56,2	0,300	299-022-002
24	45,0	20,2	42,6	38,0	11,1	280,0	23,3	68,0	141,0	56,2	0,300	299-024-002
25	45,0	20,2	42,6	38,0	11,1	292,0	23,3	68,0	141,0	56,2	0,300	299-025-002
28	51,0	20,4	49,1	46,0	12,7	325,0	23,2	59,0	164,0	61,9	0,400	299-028-002
30	51,0	20,4	49,1	46,0	12,7	348,0	23,2	59,0	164,0	61,9	0,400	299-030-002
32	51,0	20,4	49,1	46,0	12,7	372,0	23,2	59,0	164,0	61,9	0,400	299-032-002
34	60,5	28,9	57,6	50,0	14,3	520,0	30,6	46,0	249,0	70,4	0,800	299-034-002
35	60,5	28,9	57,6	50,0	14,3	535,0	30,6	46,0	249,0	70,4	0,800	299-035-002
36	60,5	28,9	57,6	50,0	14,3	551,0	30,6	46,0	249,0	70,4	0,700	299-036-002
38	60,5	28,9	57,6	50,0	14,3	581,0	30,6	46,0	249,0	70,4	0,700	299-038-002
40	67,0	31,5	64,9	60,0	14,3	650,0	32,5	41,0	294,0	76,5	0,800	299-040-002
42	67,0	31,5	64,9	60,0	14,3	682,0	32,5	41,0	294,0	76,5	0,800	299-042-002
45	73,0	37,6	74,2	65,0	15,9	761,0	33,8	33,0	339,0	81,1	1,200	299-045-002
48	73,0	37,6	74,2	65,0	15,9	812,0	33,8	33,0	339,0	81,1	1,100	299-048-002
50	73,0	37,6	74,2	65,0	15,9	845,0	33,8	33,0	339,0	81,1	1,000	299-050-002

¹⁾ bestimmt Schlüsselweite | designates wrench size

²⁾ empfohlener Naben-Außendurchmesser für Stahl 1.1191 mit 310 N/mm² Streckgrenze und Faktor C = 1
required hub outer diameter for steel 1.1191 hub assuming 310 N/mm² yield point and factor C = 1



Wellen und Bohrungstoleranzen: Alle Größen: ± 0.08 mm	Permissible tolerance on shaft and bore: All sizes: ± 0.08 mm
--	--

Drehmoment max. torque	M _t	[Nm]
Max. Axialkraft max. thrust	F _A	[kN]
Flächenpressung - Nabe contact pressure on hub	P _N	[N/mm ²]
Anzugsmoment der Mutter installation torque on nut	M _A	[Nm]
Nabenmindestdurchmesser minimum hub diameter	DM	[mm]